

FOCUS SPOT 4Z FOZUS SPOT 4Z PEARL User Guide

©2022 ADJ Products, LLC all rights reserved. Information, specifications, diagrams, images, and instructions herein are subject to change without notice. ADJ Products, LLC logo and identifying product names and numbers herein are trademarks of ADJ Products, LLC. Copyright protection claimed includes all forms and matters of copyrightable materials and information now allowed by statutory or judicial law or hereinafter granted. Product names used in this document may be trademarks or registered trademarks of their respective companies and are hereby acknowledged. All non-ADJ Products, LLC brands and product names are trademarks or registered trademarks of their respective companies.

ADJ Products, LLC and all affiliated companies hereby disclaim any and all liabilities for property, equipment, building, and electrical damages, injuries to any persons, and direct or indirect economic loss associated with the use or reliance of any information contained within this document, and/or as a result of the improper, unsafe, insufficient and negligent assembly, installation, rigging, and operation of this product.

ADJ USA | 6122 S. Eastern Ave. | Los Angeles, CA. 90040
 323-582-2650 | 323-532-2941 fax | www.adj.com | support@adj.com

ADJ Supply Europe B.V. | Junostraat 2 | 6468 EW Kerkrade, The Netherlands
 +31 (0)45 546 85 00 | +31 45 546 85 99 fax | www.adj.eu | support@adjgroup.eu

ADJ Mexico | AV Santa Ana 30 | Parque Industrial Lerma, Lerma, Mexico 52000
 +52 (728) 282-7070

DOCUMENT VERSION



Due to additional product features and/or enhancements, an updated version of this document may be available online.



Please check www.adj.com for the latest revision/update of this manual

Date	Document Version	Software Version	DMX Channels	Notes
12/27/18	1	1.04	16/18/22	Initial Release
06/07/19	1.2	N/C	N/C	System Menu Access Note
08/14/20	1.4	1.11	N/C	System Menu Update
11/22/21	1.6	N/C	N/C	Update Format
02/08/22	1.8	N/C	N/C	Added RDM

CONTENTS

General Information	4
Limited Warranty (USA Only)	5
Safety Guidelines	6
Maintenance Guidelines	8
Overview	9
Installation Instructions	10
Remote Device Management (RDM)	13
Gobos & Gobo Replacement	14
DMX Setup	15
System Menu	17
Dimming Curve	26
DMX Channel Functions and Values	27
Specifications	29
Dimensional Drawings	30
FCC Statement	31

GENERAL

INTRODUCTION

This fixture has been designed to perform reliably for years when the information in this manual are followed. Please read and understand all the instructions and guidelines carefully and thoroughly before operating this unit. This manual contains important information regarding safety, installation, use, and maintenance.

UNPACKING

Each fixture has been thoroughly tested and shipped in perfect operating condition. Carefully check the outer shipping carton for signs of any damage that may have occurred during shipping. If the outer carton appears to be damaged, carefully inspect the fixture for damage and be sure all included accessories have arrived intact. In the event damage has been found and/or parts are missing, please contact our customer support team for further instructions. Please do NOT return this fixture to your dealer without first contacting customer support at the number listed below. Please do NOT discard the outer shipping carton in the trash. Please recycle whenever possible.

CUSTOMER SUPPORT: Contact ADJ Service for any product related service and support needs. Also visit forums.adj.com with questions, comments or suggestions.

ADJ SERVICE USA - Monday - Friday 8:00am to 4:30pm PST

Voice: 800-322-6337 | Fax: 323-582-2941 | support@adj.com

ADJ SERVICE EUROPE - Monday - Friday 08:30 to 17:00 CET

Voice: +31 45 546 85 60 | Fax: +31 45 546 85 96 | support@adj.eu

REPLACEMENT PARTS please visit parts.adj.com

WARRANTY RETURNS

All returned service items, whether under warranty or not, must be freight pre-paid and accompanied by a return authorization (R.A.) number. The R.A. number must be clearly written on the outside of the return package. A brief description of the problem as well as the R.A. number must also be written down on a piece of paper and included in the shipping container. If the unit is under warranty, you must provide a copy of your proof of purchase invoice. Items returned without an R.A. number clearly marked on the outside of the package will be refused and returned at customer's expense. You may obtain an R.A. number by contacting customer support.

LIMITED WARRANTY (USA ONLY)

- A. ADJ Products, LLC hereby warrants, to the original purchaser, ADJ Products, LLC products to be free of manufacturing defects in material and workmanship for a prescribed period from the date of purchase (see specific warranty periods below). This warranty shall be valid only if the product is purchased within the United States of America, including possessions and territories. It is the owner's responsibility to establish the date and place of purchase by acceptable evidence, at the time service is sought.
- B. For warranty service you must obtain a Return Authorization number (RA#) before sending back the product—please contact ADJ Products, LLC Service Department at 800-322-6337. Send the product only to the ADJ Products, LLC factory. All shipping charges must be pre-paid. If the requested repairs or service (including parts replacement) are within the terms of this warranty, ADJ Products, LLC will pay return shipping charges only to a designated point within the United States. If the entire instrument is sent, it must be shipped in its original package. No accessories should be shipped with the product. If any accessories are shipped with the product, ADJ Products, LLC shall have no liability whatsoever for loss of or damage to any such accessories, or for the safe return thereof.
- C. This warranty is void if the serial number has been altered or removed; if the product is modified in any manner which ADJ Products, LLC concludes, after inspection, affects the reliability of the product; if the product has been repaired or serviced by anyone other than the ADJ Products, LLC factory unless prior written authorization was issued to purchaser by ADJ Products, LLC; if the product is damaged because not properly maintained as set forth in the instruction manual.
- D. This is not a service contract, and this warranty does not include maintenance, cleaning or periodic checkup. During the period specified above, ADJ Products, LLC will replace defective parts at its expense with new or refurbished parts and will absorb all expenses for warranty service and repair labor by reason of defects in material or workmanship. The sole responsibility of ADJ Products, LLC under this warranty shall be limited to the repair of the product, or replacement thereof, including parts, at the sole discretion of ADJ Products, LLC. All products covered by this warranty were manufactured after August 15, 2012, and bear identifying marks to that effect.
- E. ADJ Products, LLC reserves the right to make changes in design and/or improvements upon its products without any obligation to include these changes in any products theretofore manufactured. No warranty, whether expressed or implied, is given or made with respect to any accessory supplied with products described above. Except to the extent prohibited by applicable law, all implied warranties made by ADJ Products, LLC in connection with this product, including warranties of merchantability or fitness, are limited in duration to the warranty period set forth above. And no warranties, whether expressed or implied, including warranties of merchantability or fitness, shall apply to this product after said period has expired. The consumer's and/or Dealer's sole remedy shall be such repair or replacement as is expressly provided above; and under no circumstances shall ADJ Products, LLC be liable for any loss or damage, direct or consequential, arising out of the use of, or inability to use, this product. This warranty is the only written warranty applicable to ADJ Products, LLC Products and supersedes all prior warranties and written descriptions of warranty terms and conditions heretofore published.

LIMITED WARRANTY PERIODS

- **Non-LED Lighting Products = 1-Year (365 Days)** (Including Special Effect Lighting, Intelligent Lighting, UV lighting, Strobes, Fog Machines, Bubble Machines, Mirror Balls, Par Cans, Trussing, Lighting Stands, Power/Data Distribution, etc. excluding LED and lamps)
- **Laser Products = 1-Year (365 Days)** (excluding laser diodes which have a 6-Month Limited Warranty)
- **LED Products = 2-Year (730 Days)** (excluding batteries which have a 180 Day Limited Warranty)
PLEASE NOTE: 2-Year (730 Days) Limited Warranty ONLY applies to product purchased within the USA.
- **StarTec Series = 1-Year (365 Days)** (excluding batteries which have a 180 Day Limited Warranty)
- **ADJ DMX Controllers = 2 Year (730 Days)**
- **American Audio Products = 1 Year (365 Days)**

SAFETY GUIDELINES

This fixture is a sophisticated piece of electronic equipment. To guarantee smooth operation, it is important to follow all instructions and guidelines in this manual. ADJ is not responsible for injury and/or damages resulting from the misuse of this fixture due to the disregard of the information printed in this manual. Only qualified and/or certified personnel should perform installation of this fixture and only the original rigging parts (omega brackets) included with this fixture should be used for installation. Any modifications to the fixture and/or the included mounting hardware will void the original manufacturer's warranty and increase the risk of damage and/or personal injury.



PROTECTION CLASS 1 - FIXTURE MUST BE PROPERLY GROUNDED.



THERE ARE NO USER SERVICEABLE PARTS INSIDE THIS UNIT. DO NOT ATTEMPT ANY REPAIRS YOURSELF, AS DOING SO WILL VOID YOUR MANUFACTURER'S WARRANTY. DAMAGES RESULTING FROM MODIFICATIONS TO THIS FIXTURE AND/OR THE DISREGARD OF SAFETY INSTRUCTIONS AND GUIDELINES IN THIS MANUAL VOID THE MANUFACTURER'S WARRANTY AND ARE NOT SUBJECT TO ANY WARRANTY CLAIMS AND/OR REPAIRS.



**DO NOT PLUG FIXTURE INTO A DIMMER PACK!
NEVER OPEN THIS FIXTURE WHILE IN USE!
DISCONNECT FIXTURE FROM POWER BEFORE SERVICING!
NEVER TOUCH THE FIXTURE DURING OPERATION, AS IT MAY BE HOT!
KEEP FLAMMABLE MATERIALS AWAY FROM THE FIXTURE!**



**NEVER LOOK DIRECTLY INTO THE LIGHT SOURCE!
RETINA INJURY RISK - MAY INDUCE BLINDNESS!
SENSITIVE PERSONS MAY SUFFER AN EPILEPTIC SHOCK!**



**MAXIMUM EXTERNAL SURFACE TEMPERATURE: 185° F (85° C)
MAXIMUM AMBIENT TEMPERATURE: 104° F (40° C)**

- **DO NOT TOUCH** the fixture housing during operation.
- Turn OFF the power and allow approximately 15 minutes for the fixture to cool down before serving.
- **DO NOT** shake fixture, avoid brute force when installing and/or operating fixture.
- **DO NOT** operate fixture if the power cord is frayed, crimped, damaged and/or if any of the power cord connectors are damaged and do not insert into the fixture securely with ease.
- **NEVER** force a power cord connector into the fixture. If the power cord or any of its connectors are damaged, replace it immediately with a new one of similar power rating.
- **DO NOT** block any air ventilation slots. All fan and air inlets must remain clean and never blocked. Allow approx. 6" (15cm) between fixture and a wall for proper cooling.
- When installing fixture in a suspended environment, always use mounting hardware that is at least M10 x 25 mm, and always install fixture with an appropriately rated safety cable.
- Always disconnect fixture from main power source before performing any type of service and/or cleaning procedure.
- Only handle the power cord by the plug end, and never pull out the plug by tugging the wire portion of the cord.
- During the initial operation of this fixture, a light smoke or smell may emit from the interior of the fixture. This is a normal process and is caused by excess paint in the interior of the casing burning off from the heat associated with the lamp and will decrease gradually over time.
- Consistent operational breaks will ensure fixture will function properly for many years.
- In the event that the fixture needs to be returned for servicing, use only the original packaging and materials to transport the fixture.

SAFETY GUIDELINES

POTENTIAL INTERNAL FIXTURE DAMAGE FROM EXTERNAL SOURCES OF LIGHT BEAMS

External sources of light beams from direct sunlight, lighting moving head fixtures, and lasers, which are focused directly towards the exterior housing and/or penetrate the front lens opening of ADJ lighting fixtures, can cause severe internal damage including burning to optics, dichroic color filters, glass and metal gobos, prisms, animation wheels, frost filters, iris, shutters, motors, belts, wiring, discharge lamps, and LEDs.

This issue is not specific only to ADJ lighting fixtures, it is a common issue with lighting fixtures from all manufacturers. Although there is no true way to fully prevent this issue from happening, the guidelines below can prevent any potential damage from occurring if followed. Contact ADJ Service for more details.

DO NOT EXPOSE THE FIXTURE AND/OR FRONT LENS OPENING TO LIGHT BEAMS FROM DIRECT SUNLIGHT, OTHER LIGHTING MOVING HEAD FIXTURES, AND LASERS WHILE UNPACKING, INSTALLATION, USE, AND EXTENDED IDLE TIMES OUTDOORS.

DO NOT FOCUS A LIGHT BEAM FROM ONE LIGHTING FIXTURE DIRECTLY TOWARDS ANOTHER.

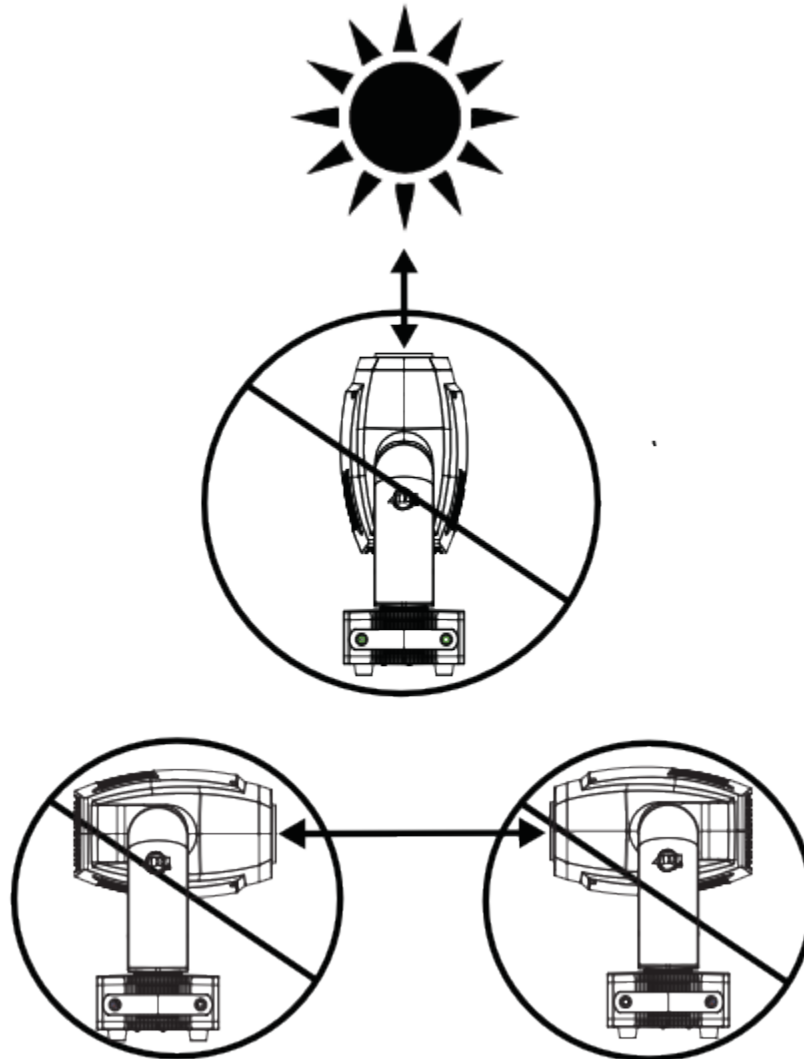

MAINTENANCE GUIDELINES



DISCONNECT POWER BEFORE PERFORMING ANY MAINTENANCE!

CLEANING

Frequent cleaning is recommended to insure proper function, optimized light output, and an extended life. The frequency of cleaning depends on the environment in which the fixture operates: damp, smoky, or particularly dirty environments can cause greater accumulation of dirt on the fixture's optics. Clean the external lens surface regularly with a soft cloth to avoid dirt/debris accumulation.

NEVER use alcohol, solvents, or ammonia-based cleaners.

MAINTENANCE

Regular inspections are recommended to insure proper function and extended life. There are no user serviceable parts inside this fixture. Please refer all other service issues to an authorized Elation service technician. Should you need any spare parts, please order genuine parts from your local Elation dealer.

Please refer to the following points during routine inspections:

- A detailed electrical check by an approved electrical engineer every three months, to make sure the circuit contacts are in good condition and prevent overheating.
- Be sure all screws and fasteners are securely tightened at all times. Loose screws may fall out during normal operation, resulting in damage or injury as larger parts could fall.
- Check for any deformations on the housing, color lenses, rigging hardware, and rigging points (ceiling, suspension, trussing). Deformations in the housing could allow for dust to enter into the fixture. Damaged rigging points or unsecured rigging could cause the fixture to fall and seriously injure a person(s).
- Electric power supply cables must not show any damage, material fatigue, or sediments.

NEVER remove the ground prong from the power cable.

FUSE REPLACEMENT

Unplug the unit from any power source it may be connected to. Once the power has been disconnected, use a flat head screw driver to unscrew the fuse holder located next to the power input. Remove the bad fuse and replace with a new one, and screw the fuse holder back in.

OVERVIEW



Service Port
LCD Display

Power Cable In/Out
Fuse: T3A/250V

Power Cable Out
3-Pin DMX Out
3-Pin DMX In



INSTALLATION INSTRUCTIONS



DO NOT INSTALL THE FIXTURE IF YOU ARE NOT QUALIFIED TO DO SO!

Fixture **MUST** be installed following all local, national, and country commercial electrical and construction codes and regulations.

Before rigging/mounting a single fixture to any metal truss/structure or placing the fixture(s) on any surface, a professional equipment installer **MUST** be consulted to determine if the metal truss/structure or surface is properly certified to safely hold the combined weight of the fixture(s), clamps, cables, and accessories.

Ambient operating temperature range is **-13°F. (-25°C) to 113°F. (45°C)**.

Fixture(s) should be installed in areas outside walking paths, seating areas, or away from areas where unauthorized personnel might reach the fixture by hand.

NEVER stand directly below the fixture(s) when rigging, removing or servicing.

Overhead fixture installation must always be secured with a secondary safety attachment, such as an appropriately rated safety cable that can hold 10 times the weight of the fixture. Allow approximately 15 minutes for the fixture to cool down before serving.



TO MAINTAIN IP RATING INTEGRITY, ALL UNUSED CONNECTION RUBBER CAPS MUST BE SEALED.

INSTALLATION INSTRUCTIONS

Screw one clamp via a M12 screw and nut into the Omega Bracket. Insert the quick-lock fasteners of the Omega Bracket into the respective holes of the fixture base. **NOTE: The clamp must be attached to the Omega Bracket before attaching the bracket to the fixture.**

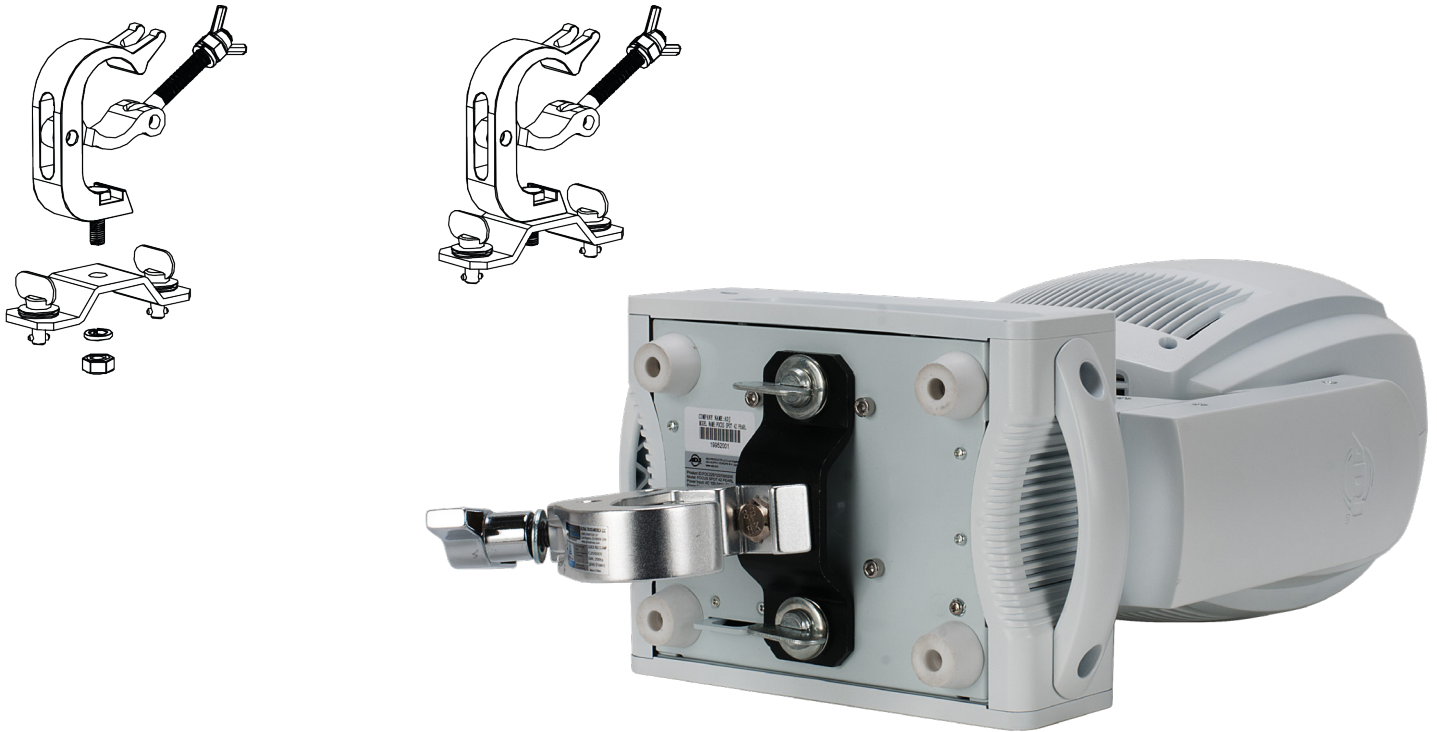

Tighten the quick-lock fasteners fully clockwise. Pull the safety-cable through the opening located on the bottom of the unit and over the trussing system or a safe fixation spot. Insert the end in the carabiner, and tighten the safety screw.

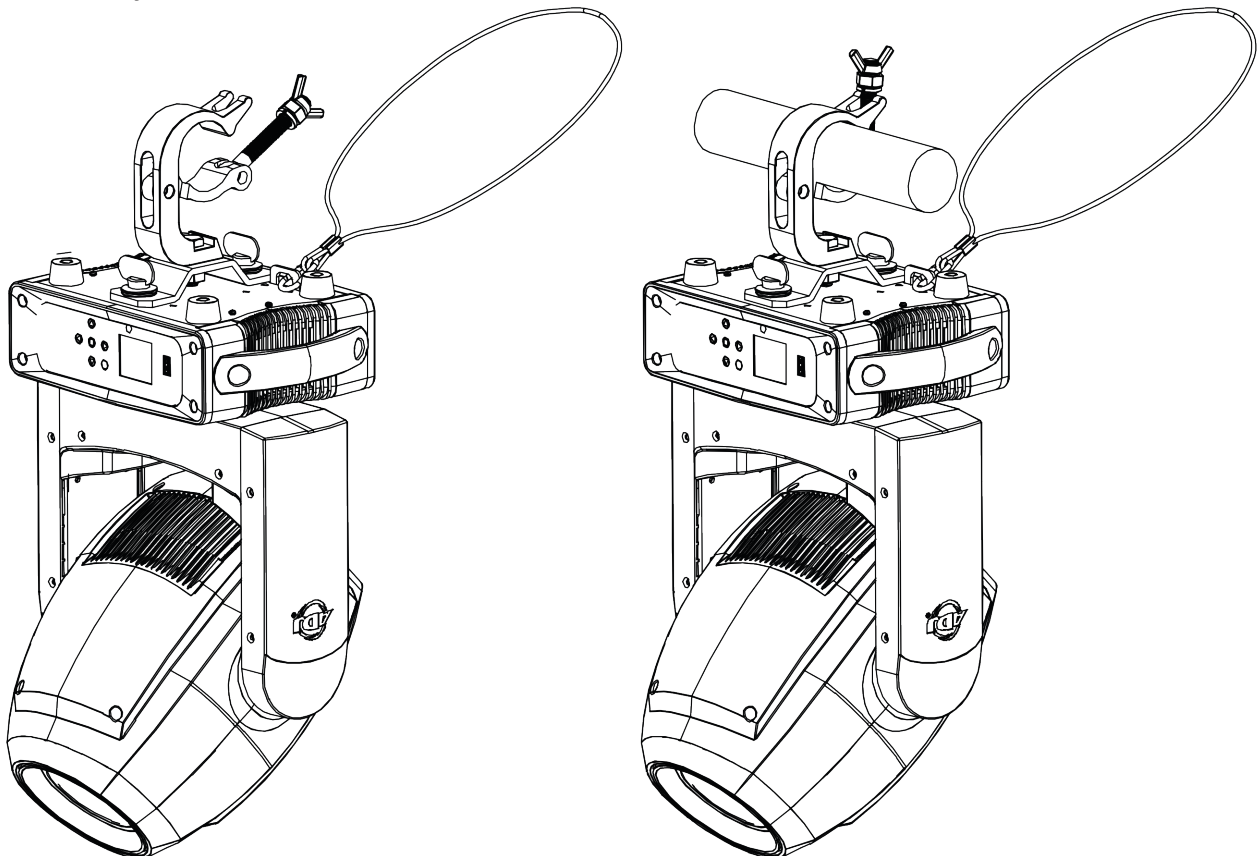

INSTALLATION INSTRUCTIONS

When installing the unit, the trussing or area of installation must be able to hold 10 times the weight without any deformation. When installing the unit must be secured with a secondary safety attachment, e.g. and appropriate safety cable. Never stand directly below the unit when mounting, removing, or servicing the unit.

Overhead mounting requires extensive experience, including calculating working load limits, installation material being used, and periodic safety inspection of all installation material and unit. If you lack these qualifications, do not attempt the installation yourself.

These installations should be checked by a skilled person once a year.



The Focus Spot 4Z is fully operational in three different mounting positions, hanging upside-down, mounted sideways on trussing, or set on a flat level surface. Always use and install a safety cable as a safety measure to prevent accidental damage and/or injury in the event the clamp fails. Never use the carrying handles for secondary attachment.

REMOTE DEVICE MANAGEMENT (RDM)

NOTE: In order for RDM to work properly, RDM enabled equipment must be used throughout the entire system, including DMX data splitters and wireless systems.

Remote Device Management (RDM) is a protocol that sits on top of the DMX512 data standard for lighting, allowing the DMX systems of the fixtures to be modified and monitored remotely. This protocol is ideal for instances in which a unit is installed in a location that is not easily accessible.

With RDM, the DMX512 system becomes bi-directional, allowing a compatible RDM enabled controller to send out a signal to devices on the wire, as well as allowing the fixture to respond (known as a *GET* command). The controller can then use its *SET* command to modify settings that would typically have to be changed or viewed directly via the unit's display screen, including the DMX Address, DMX Channel Mode, and Temperature Sensors.

Please be aware that **not all RDM devices support all RDM features**, and therefore it is important to check beforehand to ensure that the equipment that you are considering includes all of the features that you require.

The following parameters are accessible in RDM on this device:

Sensor Definition	Tilt Invert
Sensor Value	Pan Tilt Swap
Device Model Description	Display Invert
Manufacturer Label	Display Level
Device Label	Realtime Clock
DMX Personality	Power State
DMX Personality Description	Preset Playback
Device Hours	Slot Information
Comms Status	Slot Description
Status ID Description	Default Slot Value
Clear Status ID	Language
Lamp Hours	Language Capabilities
Lamp Strikes	Boot Software Version Label
Lamp State	Boot Software Version ID
Lamp Mode	Product Detail ID List
Device Power Cycles	Status Messages
Pan Invert	

GOBOS & GOBO REPLACEMENT

The gobo's featured in this unit are interchangeable. Remember when changing these gobo's that they are thin and easy to bend. Please do this process gently so you do not bend or damage gobo. Caution! Never open the unit when in use. Always disconnect the main power before attempting to change the gobos.

Locating the Gobo wheel: After disconnecting the main power, position the head with the lens facing forward. Look through lens of the unit. When looking through the front lens, position the head so that the gears are on the right side. When the gears are on the right side, the shell that needs to be unscrewed is now facing up.

1. To change a gobo, unscrew the 4 screws that secure the shell to the unit. Gently lift and remove the shell.
2. When you remove the shell you will be able to access the gobo wheel. Turn the wheel with your hand until you come across the gobo you would like to change.
3. To change the gobo you have to remove the individual gobo frames. Gently push the gobo and gobo frame (Not the wheel) away from the gobo wheel. You do not have to the push very hard. While you are pushing the gobo frame away from the wheel, gently pull the the gobo frame up and out.
4. Once the gobo frame has been removed, you will notice that a retainer ring secures the gobo in place. After the retainer ring is removed, your are able to remove the gobo.
5. Change the gobo and replace the retainer ring.
6. Insert the gobo frame back into the unit, positioning it in same way as the other gobo frames.
7. Reassemble the unit.

Inner Diameter: 19mm
Outer Diameter: 23mm
Thickness: 0.5mm



Gobo 1

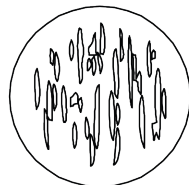

Gobo 2



Gobo 3



Gobo 4



Gobo 5

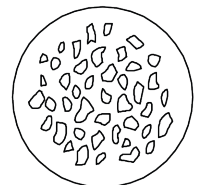

Gobo 6

DMX SETUP

DMX-512: DMX is short for Digital Multiplex. This is a universal protocol used as a form of communication between intelligent fixtures and controllers. A DMX controller sends DMX data instructions from the controller to the fixture. DMX data is sent as serial data that travels from fixture to fixture via the DATA “IN” and DATA “OUT” XLR terminals located on all DMX fixtures (most controllers only have a DATA “OUT” terminal).

DMX Linking: DMX is a language allowing all makes and models of different manufactures to be linked together and operate from a single controller, as long as all fixtures and the controller are DMX compliant. To ensure proper DMX data transmission, when using several DMX fixtures try to use the shortest cable path possible. The order in which fixtures are connected in a DMX line does not influence the DMX addressing. For example; a fixture assigned a DMX address of 1 may be placed anywhere in a DMX line, at the beginning, at the end, or anywhere in the middle. When a fixture is assigned a DMX address of 1, the DMX controller knows to send DATA assigned to address 1 to that unit, no matter where it is located in the DMX chain.

Data Cable (DMX Cable) Requirements (For DMX Operation): The Focus Spot 4Z/Focus Spot 4Z Pearl can be controlled via DMX-512 protocol. The Focus Spot 4Z/Focus Spot 4Z Pearl has 3 DMX channel modes. The DMX address is set on the front panel of the Focus Spot 4Z/Focus Spot 4Z Pearl. Your unit and your DMX controller require a standard 3-pin XLR connector for data input and data output (Figure 1). We recommend Accu-Cable DMX cables. If you are making your own cables, be sure to use standard 110-120 Ohm shielded cable (This cable may be purchased at almost all pro lighting stores). Your cables should be made with a male and female XLR connector on either end of the cable. Also remember that DMX cable must be daisy chained and cannot be split.



Notice: Be sure to follow figures two and three when making your own cables. Do not use the ground lug on the XLR connector. Do not connect the cable’s shield conductor to the ground lug or allow the shield conductor to come in contact with the XLR’s outer casing. Grounding the shield could cause a short circuit and erratic behavior.

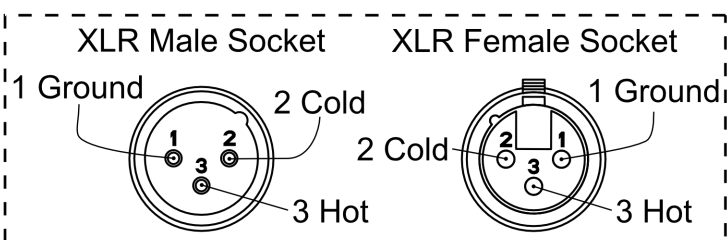
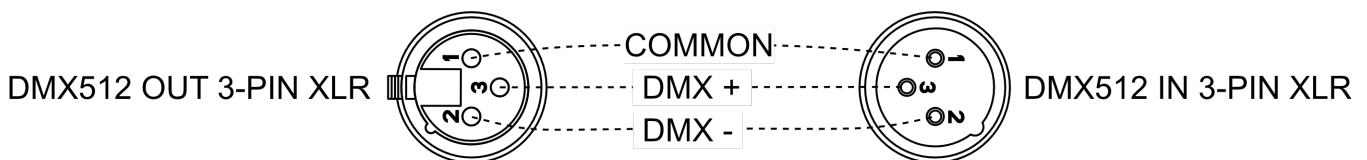

XLR Pin Configuration
Pin 1 = Ground
Pin 2 = Data Compliment (negative)
Pin 3 = Data True (positive)

DMX SETUP

SPECIAL NOTE: LINE TERMINATION

When longer runs of cable are used, you may need to use a terminator on the last unit to avoid erratic behavior. A terminator is a 110-120 ohm 1/4 watt resistor, which is connected between pins 2 and 3 of a male XLR connector (DATA + and DATA -). This unit is inserted in the female XLR connector of the last unit in your daisy chain to terminate the line. Using a cable terminator (ADJ part number Z-DMX/T) will decrease the possibilities of erratic behavior.

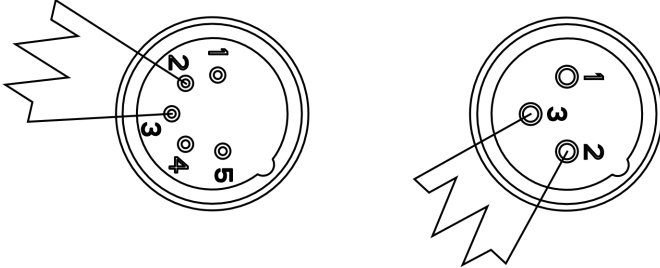

A DMX512 terminator reduces signal errors, avoiding most signal reflection interference. Connect PIN 2 (DMX-) and PIN 3 (DMX+) of the last fixture in series with a 120 Ohm, 1/4 W Resistor to terminate the DMX512.

5-Pin XLR DMX Connectors. Some manufactures use 5-pin DMX-512 data cables for DATA transmission in place of 3-pin. 5-pin DMX fixtures may be implemented in a 3-pin DMX line. When inserting standard 5-pin data cables in to a 3-pin line a cable adapter must be used, these adapters are readily available at most electric stores. The chart below details a proper cable conversion.

3-Pin XLR to 5-Pin XLR Conversion		
Conductor	3-Pin XLR Female (Out)	5-Pin XLR Male (In)
Ground/Sheld	Pin 1	Pin 1
Data Compliment (- signal)	Pin 2	Pin 2
Data True (+ signal)	Pin 3	Pin 3
Not Used		Do Not Use
Not Used		Do Not Use

DMX ADDRESSING

All fixtures should be given a DMX starting address when using a DMX controller, so the correct fixture responds to the correct control signal. This digital starting address is the channel number from which the fixture starts to “listen” to the digital control signal sent out from the DMX controller. The assignment of this starting DMX address is achieved by setting the correct DMX address on the digital control display on the fixture.

You can set the same starting address for all fixtures or a group of fixtures, or set different addresses for each individual fixture. Setting all fixtures to the same DMX address will cause all fixtures to react in the same way, in other words, changing the settings of one channel will affect all the fixtures simultaneously.

If you set each fixture to a different DMX address, each unit will start to “listen” to the channel number you have set, based on the quantity of DMX channels of each fixture. That means changing the settings of one channel will only affect the selected fixture.

In the case of the Focus Spot 4Z/Focus Spot 4Z Pearl, when in 16 channel mode you should set the starting DMX address of the first unit to 1, the second unit to 17 (16 + 1), the third unit to 33 (17 + 16), and so on. (See the chart below for more details.)

Channel Mode	Unit 1 Address	Unit 2 Address	Unit 3 Address	Unit 4 Address
16 Channels	1	17	33	49
18 Channels	1	19	37	55
22 Channels	1	23	45	67

SYSTEM MENU

The fixture includes an easy to navigate system menu control panel display where all necessary settings and adjustments are made. (See image below) During normal operation, pressing the **MODE** button once will access the fixture's main menu. Once in the main menu, you can navigate through the different functions and access the sub-menus with the **UP** and **DOWN** buttons. When you reach a field that requires adjusting, press the **ENTER** button to access that field and use the **UP** and **DOWN** buttons to adjust the field. Pressing the **ENTER** button once more will confirm your setting. You may exit the main menu at any time without making any adjustments by pressing the **MODE** button.



SYSTEM MENU

MAIN MENU	SUB MENU	OPTIONS / VALUES (Default Settings in BOLD)		DESCRIPTION
USER MODE	User Mode	Standard (18 Channel Mode) Basic (16 Channel Mode) Extend (22 Channel Mode) User A User B User C		
	Edit A Edit B Edit C	Max. Channel PAN		
FUNCTION	Status	No DMX Mode P.Reverse T.Reverse Pan Degree Feedback Hibernation	Hold /Auto/Black ON/OFF ON/OFF 630/540 ON/OFF Speed 1 ~ 4 OFF, 01M~99M, 15M	
	Dim Mode	Standard Stage TV Architectur Theatre Stage2		
	Temp. C/F	Celsius fahrenheit		
	Gamma	2.0/2.2/2.4/2.6/2.8		
	Frequency	900Hz , 1000Hz, 1100Hz, 1300Hz, 1400Hz, 1500Hz, 2500Hz, 4000Hz, 5000Hz, 15KHz		
	Fan Set	Head Fan	Auto , High, Low	
	LCD.Set	Backlight FlipDisplay Key Lock Disp Flash	02~60m < 50m > ON/OFF ON/OFF/ON1 ON/OFF	
	Disp.Set	Chan.Value Secondary Set Auto.Prog	PAN... Sec1, Sec2, Sec3 Primary/Alone	
	USB Update	OFF/ON		
	DFSE	ON/OFF		
	Time.Info	CurrentTime Total Time Last Time Timer PIN Clear Last Clear Total	Current Running Time (Hours) Total Running Time (Hours) Total Running Time (Hours) Last Time Clear: (Password= 060) ON/OFF ON/OFF	
	Temp.Info	T:XXX		
	Fan Speed	Fan1:XXXX RPM Fan2:XXXX RPM		
	Error. Info	NONE/Pan, Tilt...		
	Model. Info	FOCUS SPOT 4Z		
Software.V	1U:VX.X.X 2U:VX.X.X 3U:VX.X.X			

SYSTEM MENU

MAIN MENU	SUB MENU	OPTIONS / VALUES (Default Settings in BOLD)	DESCRIPTION
TEST	Reset.Motor	All Pan & Tilt Color & Gobo	
	TestChannel	Pan, Pan Fine, Tilt, Tilt Fine, ColorWheel, Gobo, RotGobo, Strobe, Dimmer, Dim Fine, Prism1, Prism1Rot, Prism1 Fine, Prism2, Prism2Rot, Prism2Fine, Focus, Zoom, ZoomFine, DimMode, P, T Speed, Reset, Prog	
	Panel.Ctrl	Pan, Pan Fine, Tilt, Tilt Fine, ColorWheel, Gobo, RotGobo, Strobe, Dimmer, Prism1, Prism1Rot, Prism2, Prism2Rot, Focus, Zoom, DimMode, P, T Speed, Reset, Prog	
	Calibrate	Password Pan, Tilt, ColorWheel, Gobo, RotGobo, Prism1, Prism1Rot, Prism2, Prism2Rot, Focus, Zoom	Password= 050
PROGRAM	Select.Prog	Prog.Part 1 = Program 1~9 Prog.Part 2 = Program 1~9 Prog.Part 3 = Program 1~9	Program 1 Program 2 Program 3
	Edit.Prog	Program 1 : Program 9	Program Test Step 01=SCxxx Step 64=SCxxx
	Edit.Scene	Edit Scene 001 ~EditScene250	Pan, Tilt, ... Fade Time Scene Time

SYSTEM MENU - OPERATING INSTRUCTIONS

Access the main menu by pressing MODE. Use the UP, DOWN, RIGHT, & LEFT buttons to browse the menu. Press ENTER to access the desired menu, then use UP and DOWN buttons to scroll through the selections. To confirm a selection, press ENTER. Exit any menu by pressing MODE. The unit will automatically exit the menus if no buttons are pressed after 10-seconds.

System Menu Access: To access the system menu when the fixture is not powered using the internal battery, press and hold the MODE button to illuminate the LCD screen until the DMX address is displayed. Then navigate to the desired system menu.

SET ADDRESS - adjust/set DMX address.

1. Access the main menu and press the **UP** or **DOWN** buttons until “**Receive**” is highlighted, then press **ENTER**.
2. Press **ENTER** when “Set Address” is displayed.
3. Use the **UP/DOWN** buttons to adjust the **DMX** address.
4. Press the **ENTER** button to confirm your address or press the **MODE** button to exit.

USER MODE - adjust/select DMX Channel mode.

1. Press the **MODE** button to access the main menu. Use the **UP/DOWN** buttons to scroll to “**User Mode**”, then press **ENTER**.
2. Use the **UP/DOWN** buttons to scroll through the 3 DMX Channel Modes.
 - Basic Mode - 16 Channel Mode.
 - Standard Mode - 18 Channel Mode.
 - Extended Mode - 22 Channel Mode.

User Mode A B C - These are user customized DMX modes. Select either of these modes and set the number of DMX Channels, and assign the function of each channel.

3. Press ENTER to confirm settings, or press the MODE button to exit.

SYSTEM MENU

NO DMX MODE - Use this function to set 1 of 3 available modes with DMX signal loss.

1. Press the **MODE** button to access the main menu. Use the **UP/DOWN** buttons to scroll to “**Function**”, then press **ENTER**.
2. Use the **UP/DOWN** buttons to select “**Status**”, then press **ENTER**.
3. Use the **UP/DOWN** buttons to select “**No DMX Mode**”, then press **ENTER**.
4. “**Hold**” (Last DMX setting), “**Black**” (Blackout), or “**Auto**” (Auto Program) will be displayed. Use the **UP/DOWN** buttons to scroll through settings.
5. Press the **ENTER** button to confirm your selection, or press the **MODE** button to exit.

PAN INVERSE - Use this function to reverse the Pan movement.

1. Press the **MODE** button to access the main menu. Use the **UP/DOWN** buttons to scroll to “**Function**”, then press **ENTER**.
2. Use the **UP/DOWN** buttons to select “**Status**”, then press **ENTER**.
3. Use the **UP/DOWN** buttons to select “**P. Reverse**”, then press **ENTER**.
4. Depending on which direction is set for P. Reverse, either “**Off**” or “**On**” will be displayed. Use the **UP/DOWN** buttons to scroll through settings.
5. Press the **ENTER** button to confirm your selection, or press the **MODE** button to exit.

TILT INVERSE - Use this function to reverse the left head Tilt movement. This function is used with DMX mode.

1. Press the **MODE** button to access the main menu. Use the **UP/DOWN** buttons to scroll to “**Function**”, then press **ENTER**.
2. Use the **UP/DOWN** buttons to select “**Status**”, then press **ENTER**.
3. Use the **UP/DOWN** buttons to select “**T. Reverse**”, then press **ENTER**.
4. Depending on which direction is set for T. Reverse, either “**Off**” or “**On**” will be displayed. Use the **UP/DOWN** buttons to scroll through settings.
5. Press the **ENTER** button to confirm your selection, or press the **MODE** button to exit.

PAN DEGREE - Use this function to change the pan degree from 630 to 540. This function is used with DMX mode.

1. Press the **MODE** button to access the main menu. Use the **UP/DOWN** buttons to scroll to “**Function**”, then press **ENTER**.
2. Use the **UP/DOWN** buttons to select “**Status**”, then press **ENTER**.
3. Use the **UP/DOWN** buttons to select “**Pan Degree**”, then press **ENTER**.
4. Depending on which degree is set for Pan Degree was set, either “**540**” or “**630**” will be displayed. Use the **UP/DOWN** buttons to scroll through settings.
5. Press the **ENTER** button to confirm your selection, or press the **MODE** button to exit.

FEEDBACK - Use this function to change between pan-and-tilt position feedback pan degree from 630 to 540. This function is used with DMX mode.

1. Press the **MODE** button to access the main menu. Use the **UP/DOWN** buttons to scroll to “**Function**”, then press **ENTER**.
2. Use the **UP/DOWN** buttons to select “**Status**”, then press **ENTER**.
3. Use the **UP/DOWN** buttons to select “**Pan Degree**”, then press **ENTER**.
4. Depending on which degree is set for Pan Degree was set, either “**540**” or “**630**” will be displayed. Use the **UP/DOWN** buttons to scroll through settings.
5. Press the **ENTER** button to confirm your selection, or press the **MODE** button to exit.

MOVEMENT SPEED - Use this function to set the pan-and-tilt movement speed. This function is used with DMX mode.

1. Press the **MODE** button to access the main menu. Use the **UP/DOWN** buttons to scroll to “**Function**”, then press **ENTER**.
2. Use the **UP/DOWN** buttons to select “**Status**”, then press **ENTER**.
3. Use the **UP/DOWN** buttons to select “**Move. Speed**”, then press **ENTER**.
4. Depending on MOVEMENT SPEED setting, “**Speed1**”, “**Speed2**”, “**Speed3**”, or “**Speed4**” will be displayed. Use the **UP/DOWN** buttons to scroll through settings.
5. Press the **ENTER** button to confirm your selection, or press the **MODE** button to exit.

SYSTEM MENU

HIBERNATION - Use this function to turn off LEDs and step-motors without a DMX signal after 15 minutes (factory default). The fixture will reset with a reactivated DMX signal.

1. Press the **MODE** button to access the main menu. Use the **UP/DOWN** buttons to scroll to “**Function**”, then press **ENTER**.
2. Use the **UP/DOWN** buttons to select “**Status**”, then press **ENTER**.
3. Use the **UP/DOWN** buttons to select “**Hibernation**”, then press **ENTER**.
4. The current standby signal will be displayed. Use the **UP/DOWN** buttons to adjust hibernation period between “**01M-99M**” or “**Off**”.
5. Press the **ENTER** button to confirm your selection, or press the **MODE** button to exit.

DIMMER MODE - Use this function to change the dimmer curve setting (see Dimmer Curve Chart on page 25).

1. Press the **MODE** button to access the main menu. Use the **UP/DOWN** buttons to scroll to “**Function**”, then press **ENTER**.
2. Use the **UP/DOWN** buttons to select “**Dim Mode**”, then press **ENTER**.
3. Use the **UP/DOWN** buttons to find and select applicable curve setting.
4. The current dimmer curve will be displayed. Use the **UP/DOWN** buttons to select applicable dimmer curve.
5. Press the **ENTER** button to confirm your selection, or press the **MODE** button to exit.

TEMPERATURE C/F - Use this function to change the temperature display between Celsius and Fahrenheit.

1. Press the **MODE** button to access the main menu. Use the **UP/DOWN** buttons to scroll to “**Function**”, then press **ENTER**.
2. Use the **UP/DOWN** buttons to select “**Temp. C/F**”, then press **ENTER**.
3. Depending on current setting, either “**Celsius**” or “**Fahrenheit**” will be displayed. Use the **UP/DOWN** buttons to highlight applicable temperature scale.
4. Press the **ENTER** button to confirm your selection, or press the **MODE** button to exit.

GAMMA ADJUSTMENT - Use this function to adjust gamma setting. This feature is primarily used when shooting video.

1. Press the **MODE** button to access the main menu. Use the **UP/DOWN** buttons to scroll to “**Function**”, then press **ENTER**.
2. Use the **UP/DOWN** buttons to select “**Gamma**”, then press **ENTER**.
3. Use the **UP/DOWN** buttons to highlight applicable setting.
4. Press the **ENTER** button to confirm your selection, or press the **MODE** button to exit.

FREQUENCY ADJUSTMENT - Use this function to adjust dimming frequency. This feature is mostly used when shooting video for a flicker free operation.

1. Press the **MODE** button to access the main menu. Use the **UP/DOWN** buttons to scroll to “**Function**”, then press **ENTER**.
2. Use the **UP/DOWN** buttons to select “**Frequen**”, then press **ENTER**.
3. Use the **UP/DOWN** buttons to highlight applicable setting.
4. Press the **ENTER** button to confirm your selection, or press the **MODE** button to exit.

FAN SET - Use this function to adjust the moving head fan speed.

1. Press the **MODE** button to access the main menu. Use the **UP/DOWN** buttons to scroll to “**Function**”, then press **ENTER**.
2. Use the **UP/DOWN** buttons to select “**Fan Set**”, then press **ENTER**.
3. Use the **UP/DOWN** buttons to highlight “**Head Fan**” and press **ENTER**.
4. Use the **UP/DOWN** buttons to adjust the head fan speed.
5. Press the **ENTER** button to confirm your selection, or press the **MODE** button to exit..

SYSTEM MENU

BACKLIGHT. - Use this function to adjust the display LCD backlight time from 2-60 minutes.

1. Press the **MODE** button to access the main menu. Use the **UP/DOWN** buttons to scroll to “**Function**”, then press **ENTER**.
2. Use the **UP/DOWN** buttons to select “**LCD.Set**”, then press **ENTER**.
3. Use the **UP/DOWN** buttons to highlight “**Backlight**” and press **ENTER**.
4. The current shutoff time will be displayed (“**05m**” is the default setting). Use the **LEFT/RIGHT** buttons to adjust the shutoff time between 02m-60m, or “Off.”
5. Press the **ENTER** button to confirm your selection, or press the **MODE** button to exit.

FLIP DISPLAY - Use this function to rotate (flip) the display 180°.

1. Press the **MODE** button to access the main menu. Use the **UP/DOWN** buttons to scroll to “**Function**”, then press **ENTER**.
2. Use the **UP** or **DOWN** buttons to select “**LCD.Set**”, then press **ENTER**.
3. Use the **UP** or **DOWN** buttons to select “**Flip Display**”, then press **ENTER**.
4. Depending on which direction is set for Flip Display, either “**Off**” or “**On**” will be displayed. Use the **LEFT/RIGHT** buttons to flip between settings.
5. Press the **ENTER** button to confirm your selection, or press the **MODE** button to exit.

KEY LOCK - Activating this function locks the buttons after 15 seconds.=.

1. Press the **MODE** button to access the main menu. Use the **UP/DOWN** buttons to scroll to “**Function**”, then press **ENTER**.
2. Use the **UP** or **DOWN** buttons to select “**LCD.Set**”, then press **ENTER**.
3. Use the **UP** or **DOWN** buttons to select “**Key Lock**”, then press **ENTER**.
4. Use the **LEFT/RIGHT** buttons to scroll through Key Lock options, then press **ENTER**.
 - “**OFF**” - The keypad is unlocked. Press the **MODE** button to activate the keypad.
 - “**ON**” - This is keypad lock. Press the **MODE** button for at least 5-seconds to unlock the keypad.
 - “**ON1**” - Use this setting to prevent accidental keypad unlocking. A code needs to be entered to unlock keypad. Press **UP, DOWN, UP, DOWN, & ENTER** in that order.
5. Press the **ENTER** button to confirm your selection, or press the **MODE** button to exit.

DISPLAY FLASH - Use this function to have display flash with the loss of a DMX signal.

1. Press the **MODE** button to access the main menu. Use the **UP/DOWN** buttons to scroll to “**Function**”, then press **ENTER**.
2. Use the **UP** or **DOWN** buttons to select “**LCD.Set**”, then press **ENTER**.
3. Use the **UP** or **DOWN** buttons to select “**DispFlash**”, then press **ENTER**.
4. Depending on current setting, either “**Off**” or “**On**” will be displayed. Use the **LEFT/RIGHT** buttons to scroll through settings.
5. Press the **ENTER** button to confirm your selection, or press the **MODE** button to exit.

CHANNEL VALUE - Use this function to display DMX value of each DMX channel in use.

1. Press the **MODE** button to access the main menu. Use the **UP/DOWN** buttons to scroll to “**Function**”, then press **ENTER**.
2. Use the **UP** or **DOWN** buttons to select “**Disp.Set**”, then press **ENTER**.
3. Use the **UP** or **DOWN** buttons to select “**Chan. Value**”, then press **ENTER**.
4. A DMX channel will now display. Example: Pan, Rotation, LEDs... The channel DMX value will be displayed when you press **ENTER**.
5. Press the **MODE** button to exit.

SECONDARY SET - Use this function to designate unit as secondary in a Primary-Secondary configuration.

1. Press the **MODE** button to access the main menu. Use the **UP/DOWN** buttons to scroll to “**Function**”, then press **ENTER**.
2. Use the **UP** or **DOWN** buttons to select “**Disp.Set**”, then press **ENTER**.
3. Use the **UP** or **DOWN** buttons to select “**Secondary Set**”, then press **ENTER**.
4. Depending on current setting, “**Secondary 1**”, “**Secondary 2**”, or “**Secondary 3**” will be displayed. Use the **UP/DOWN** buttons to scroll through settings.
5. Press the **ENTER** button to confirm your selection, or press the **MODE** button to exit.

SYSTEM MENU

AUTO PROGRAM - This function allows the internal programs to run in either a stand-alone or primary/secondary mode. In "**Primary**" mode, the fixture will send DMX data to other fixtures connected via DMX cable. In "**Alone**" mode, the fixture will operate as a single fixture. The program for this mode is selected in the "**Program**" section of the control menu. You can set the number of steps under "**Edit. Prog**". You can edit the individual scenes under "**Edit Scenes**".

1. Press the **MODE** button to access the main menu. Use the **UP/DOWN** buttons to scroll to "**Function**", then press **ENTER**.
2. Use the **UP/DOWN** buttons to select "**Disp.Set**", then press **ENTER**.
3. Use the **UP/DOWN** buttons to highlight "**Auto. Prog**" and press **ENTER**.
4. Either "**Primary**" or "**Alone**" will be displayed. Use the **UP/DOWN** buttons to scroll through settings.
5. Press the **ENTER** button to confirm your selection, or press the **MODE** button to exit.

DEFAULT SETTINGS - Use this function to restore factory settings.

1. Press the **MODE** button to access the main menu. Use the **UP/DOWN** buttons to scroll to "**Function**", then press **ENTER**.
2. Use the **UP** or **DOWN** buttons to select "**DFSE**", then press **ENTER**.
3. Depending on setting, either "**Off**" or "**On**" will be displayed. Select "**On**" to restore fixture to factory settings.
4. Press the **ENTER** button to confirm your selection, or press the **MODE** button to exit.

USB UPGRADE FILE - This submenu is used for any future software updates. Check www.adj.com and this units webpage for any software updates. Download the software update to a flash stick and plug the flash stick into the Service Port slot located on the front of the unit.

1. Contact ADJ customer service for help when updating software.

TIME INFO - Use this function to check current running time, total running time, and last clear time. This submenu also allows a user to clear/set "Total Time" and "Last Time" hours.

1. Press the **MODE** button to access the main menu. Use the **UP/DOWN** buttons to scroll to "**Information**", then press **ENTER**.
2. Use the **UP** or **DOWN** buttons to select "**Time.Info**", then press **ENTER**.
3. Use the **UP** or **DOWN** buttons to scroll through Time Information selections:
 - "**Current Time**" - This will display the current fixture run time in hours. Press the **MODE** button to exit.
 - "**Total Time**" - This displays the total fixture run time in hours. Press the **MODE** button to exit.
 - "**Last Time**" - This displays the last time the run time was cleared. Press the **MODE** button to exit.
 - "**Time PIN**" - Use this function to enable clearing of "**Last Time**" and "**Total Time**" functions.
 - "**Clear Last**" - Use this function to clear "Last Time" counter. Access "Time PIN" and press **ENTER**. Use the **UP/DOWN** buttons to set "PIN" to "**050**" and press **ENTER**. Return to the "**Clear Last**" function and press **ENTER**. Press **LEFT/RIGHT** buttons until selection is displayed and press **ENTER** to confirm. "**ON**" will clear the time. "**OFF**" returns user to Time Menu display.
 - "**Clear Total**" - Use this function to clear "**Total Time**" counter. Access "**Time PIN**" and press **ENTER**. Use the **UP/DOWN** buttons to set "PIN" to "**060**" and press **ENTER**. Return to the "**Clear Total**" function and press **ENTER**. Press **LEFT/RIGHT** buttons until selection is displayed and press **ENTER** to confirm. "**ON**" will clear the time. "**OFF**" returns user to Time Menu display.

TEMPERATURE INFO - Use this function to display moving head temperature.

1. Press the **MODE** button to access the main menu. Use the **UP/DOWN** buttons to scroll to "**Information**", then press **ENTER**.
2. Use the **UP** or **DOWN** buttons to select "**Temp. Info**", then press **ENTER**.
3. "**T:XXX**" is displayed. "**XXX**" represents the current temperature of the moving head.
4. Press the **ENTER** or **MODE** button to exit.

FAN SPEED - Use this function to adjust the base fan speed.

1. Press the **MODE** button to access the main menu. Use the **UP/DOWN** buttons to scroll to "**Information**", then press **ENTER**.
2. Use the **UP** or **DOWN** buttons to select "**Fan Speed**", then press **ENTER**.
3. The current fan speeds for "**Fan1**" and "**Fan2**" will be displayed.
4. Press the **ENTER** or **MODE** button to exit.

SYSTEM MENU

ERROR INFO - This submenu will display any function errors that may occur. Please contact ADJ customer support for additional information if any error warnings appear and there is any uncertainty about what action needs to be taken.

1. Press the **MODE** button to access the main menu. Use the **UP/DOWN** buttons to scroll to “**Information**”, then press **ENTER**.
2. Use the **UP/DOWN** buttons to select “**Error. Info**”, then press **ENTER**.
3. Any errors that may have occurred will be displayed. Press the **MODE** button to exit.

MODEL INFORMATION - Use this function to display model name.

1. Press the **MODE** button to access the main menu. Use the **UP/DOWN** buttons to scroll to “**Information**”, then press **ENTER**.
2. Use the **UP** or **DOWN** buttons to select “**Model.Info**”, then press **ENTER**.
3. Model name will be displayed. Press the **MODE** button to exit.

SOFTWARE VERSION - Use this function to display current software version.

1. Press the **MODE** button to access the main menu. Use the **UP/DOWN** buttons to scroll to “**Information**”, then press **ENTER**.
2. Use the **UP** or **DOWN** buttons to select “**Software.V**”, then press **ENTER**.
3. The current software version will be displayed. Press the **MODE** button to exit.

RESET MOTOR - Use this function to display current software version.

1. Press the **MODE** button to access the main menu. Use the **UP/DOWN** buttons to scroll to “**Test**”, then press **ENTER**.
2. Use the **UP** or **DOWN** buttons to select “**Reset.Motor**”, then press **ENTER**.
3. Press the **ENTER** button to reset fixture motor, or press the **MODE** button to exit.

TEST CHANNEL - Use this function to test each of the channel functions.

1. Press the **MODE** button to access the main menu. Use the **UP/DOWN** buttons to scroll to “**Test**”, then press **ENTER**.
2. Use the **UP** or **DOWN** buttons to select “**TestChannel**”, then press **ENTER**.
3. Use the **UP** or **DOWN** buttons to scroll through channel functions.
4. Press the **ENTER** button to confirm your selection, or press the **MODE** button to exit.

PANEL CONTROL - Use this function to make fine adjustments.

1. Press the **MODE** button to access the main menu. Use the **UP/DOWN** buttons to scroll to “**Test**”, then press **ENTER**.
2. Use the **UP** or **DOWN** buttons to select “**Panel. Ctrl**”, then press **ENTER**.
3. Use the **UP** or **DOWN** buttons to scroll through various functions.
4. Press the **ENTER** button to confirm your selection, or press the **MODE** button to exit.

CALIBRATE - Use this function to calibrate/adjust the positions of the effect wheels. The Calibration password is “050”. **NOTE: ONLY QUALIFIED TECHNICIANS SHOULD PERFORM THIS FUNCTION.**

1. Press the **MODE** button to access the main menu. Use the **UP/DOWN** buttons to scroll to “**Test**”, then press **ENTER**.
2. Use the **UP** or **DOWN** buttons to select “**Calibrate**”, then press **ENTER**.
3. “**XXXX**” will be displayed. Use the **UP/DOWN** buttons set the “**PIN**” to “**050**” and press **ENTER**.
4. Press the **ENTER** button to confirm your selection, or press the **MODE** button to exit.

PROGRAM

EDIT PROGRAM - The fixture comes equipped with a built-in DMX recorder that allows custom programs to be installed and recalled directly from the fixture’s control board. Programs can be created and stored using the fixture’s control board or by using an external DMX controller.

Select.Prog – This function allows the user to select one of nine of the user defined built-in programs. This program is then accessed in “Function Mode” under “Program Run.”

Edit.Prog – This function allows the user to edit the built-in programs.

Edit.Scene – This function allows the user to edit or define the actual scenes that are stored in the user defined built-in programs that are accessed in the previous step.

SYSTEM MENU

PRIMARY-SECONDARY

This function will allow you to link units to run in a Primary-Secondary set-up. In a **Primary-Secondary** set up, one unit will act as the controlling unit and the others will react to the controlling units built-in programs. Any unit can act as a Primary or as a Secondary however, only one unit can be programmed to act as the “Primary.”

Primary-Secondary Connections and Settings:

1. Daisy chain your units via the XLR connector on the rear of the unit. Use standard XLR data cables to link your units together. Remember that the Male XLR connector is the input and the Female XLR connector is the output. The first unit in the chain (primary) will use the female XLR connector only. The last unit in the chain will use the male XLR connector only.
2. Connect the first “Secondary” unit to the “Primary.”
3. **Primary Unit:**
 - Press the MODE button to access the main menu. Press the UP or DOWN buttons so that “Function” is highlighted, then press ENTER.
 - Press the UP or DOWN buttons until “**Disp.Set**” is displayed, press ENTER.
 - Press the UP or DOWN buttons until “**Auto. Prog**” is displayed, and press ENTER.
 - Either “**Primary**” or “**Alone**” will be displayed. Use the UP or DOWN buttons to highlight “Primary”.
 - Press the ENTER button to confirm your selection.
4. **Secondary Unit(s):**
 - Press the MODE button to access the main menu. Press the UP or DOWN buttons so that “Function” is highlighted, then press ENTER.
 - Press the UP or DOWN buttons until “**Disp.Set**” is highlighted, then press ENTER.
 - Press the UP or DOWN buttons until “**Secondary Set**” is highlighted, then press ENTER.
 - Either “**Secondary 1**”, “**Secondary 2**”, or “**Secondary 3**” will be displayed. Use the **UP/DOWN** buttons to find your desired secondary setting.
5. Press the **ENTER** button to confirm your selection.

DIMMING CURVE

The fixture includes 6 different dimming curve modes which can be selected from either the system menu or via DMX. The graph below provides details on each dimming curve mode.

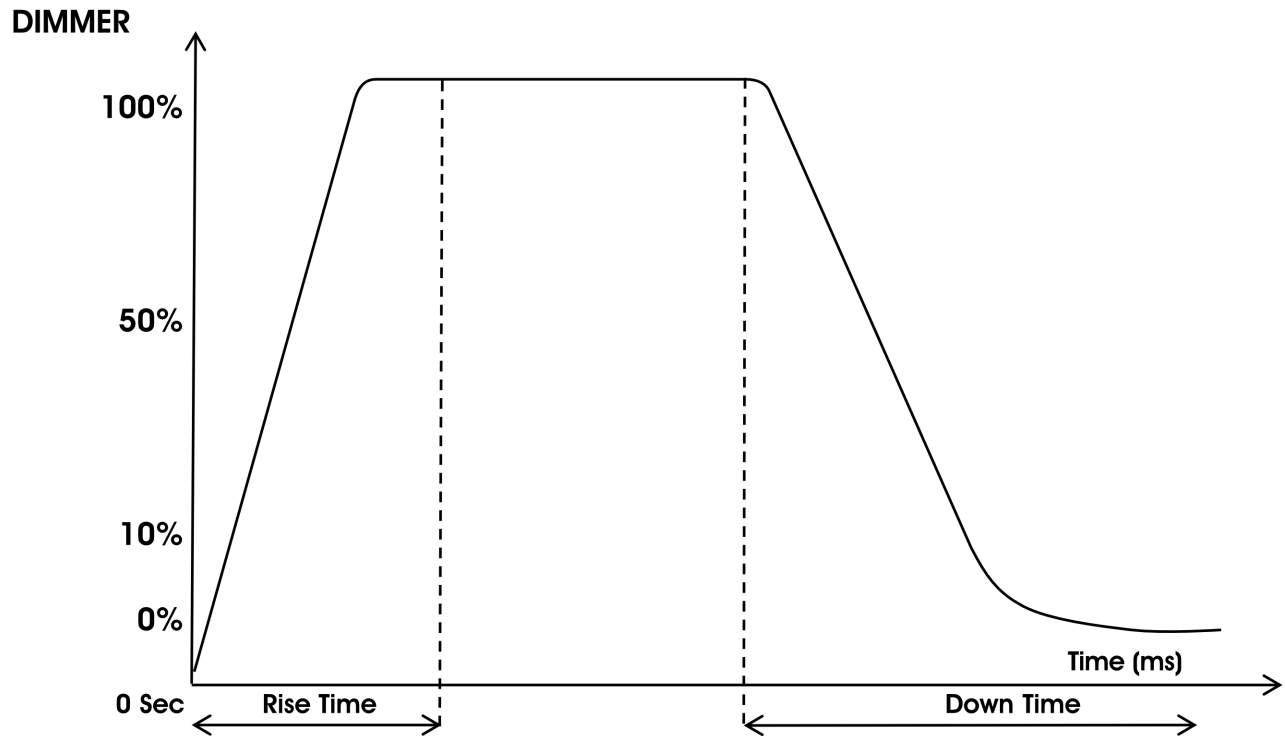

Dimming Curve Ramp Effect	0 sec Fade Time		1 sec Fade Time	
	Rise Time (ms)	Down Time (ms)	Rise Time (ms)	Down Time (ms)
Standard (default)	0	0	0	0
Stage	780	1100	1540	1660
TV	1180	1520	1860	1940
Architectural	1380	1730	2040	2120
Theatre	1580	1940	2230	2280
Stage 2	0	1100	0	1660

DMX CHANNELS / VALUES / FUNCTIONS

Features subject to change without notice

Rotation direction (Clockwise/Counter-Clockwise) and control of effects depends on head orientation and Pan/Tilt settings

MODE / CHANNEL			VALUE	FUNCTION
Basic	Standard	Extended		
1	1	1	000-255	PAN Movement 8-bit Pan Movement by 630/540
	2	2	000-255	PAN Fine 16-bit Fine control Pan movement
2	3	3	000-255	Tilt Movement 8-bit Tilt Movement
	4	4	000-255	Tilt Fine 16-bit Fine control of Tilt movement
3	5	5		Color Wheel
			000-007	White
			008-014	Red
			015-021	Orange
			022-028	Yellow
			029-035	Green
			036-042	Blue
			043-049	Pink
			050-056	Cyan
			057-063	Magenta
			064-127	Color Mixing
			128-189	Color Wheel Clockwise Rotation Fast-Slow
			190-193	Nothing
194-255	Color Wheel Counter-Clockwise Rotation Slow-Fast			
4	6	6		Gobo Wheel
			000-004	Open
			005-019	Gobo 1
			020-034	Gobo 2
			035-049	Gobo 3
			050-064	Gobo 4
			065-079	Gobo 5
			080-094	Gobo 6
			095-109	Gobo 1 Shake Slow-Fast
			110-124	Gobo 2 Shake Slow-Fast
			125-139	Gobo 3 Shake Slow-Fast
			140-154	Gobo 4 Shake Slow-Fast
			155-169	Gobo 5 Shake Slow-Fast
			170-189	Gobo 6 Shake Slow-Fast
			190-221	Gobo Wheel Clockwise Rotation Fast-Slow
			222-223	Nothing
224-255	Gobo Wheel Counter-Clockwise Slow-Fast			
5	7	7		Gobo Rotation
			000-127	Gobo Rotation Indexing
			128-191	Gobo Rotation Clockwise Fast-Slow
			192-255	Gobo Rotation Counter-Clockwise Slow-Fast
6	8	8		Shutter & Strobing
			000-031	Shutter Closed (No Function)
			032-063	Shutter Open
			064-095	Strobing Slow-Fast
			096-127	Shutter Open
			128-159	Pulse Strobing Slow-Fast
			160-191	Shutter Open
			192-223	Random Strobing Slow-Fast
224-255	Shutter Open			
7	9	9		Master Dimmer
			000-255	Intensity 0 to 100%
		10	000-255	Dimmer Fine 16-bit

DMX CHANNELS / VALUES / FUNCTIONS

Features subject to change without notice

Rotation direction (Clockwise/Counter-Clockwise) and control of effects depends on head orientation and Pan/Tilt settings

MODE / CHANNEL			VALUE	FUNCTION
Basic	Standard	Extended		
8	10	11		Prism 1
			000-031	Open
			032-255	6 Facet Circular Prism
9	11	12		Prism 1 Indexing & Rotation
			000-127	Prism 1 Indexing
			128-189	Clockwise Rotation Fast-Slow
			190-193	No Rotation
			194-255	Counter-Clockwise Rotation Slow-Fast
		13	000-255	Prism 1 Indexing Fine 16-bit
10	12	14		Prism 2
			000-031	Open
			032-063	5 Facet Linear Prism
11	13	15		Prism 2 Indexing & Rotation
			000-127	Prism 2 Indexing
			128-189	Clockwise Rotation Fast-Slow
			190-193	No Rotation
			194-255	Counter-Clockwise Rotation Slow-Fast
		16	000-255	Prism 2 Indexing Fine 16-bit
12	14	17	000-255	Focus Continuous adjustment from far to near
13	15	18	000-255	Zoom Zoom from min. to max. beam angle (Wide to Narrow)
		19	000-255	Zoom Fine 16-bit
14	16	20		Dim Curves
			000-020	Standard
			021-040	Stage
			041-060	TV
			061-080	Architectural
			081-100	Theatre
			101-120	Stage 2
			121-255	Default Unit Setting
15	17	21	000-255	Pan/Tilt Speed Max. to min. speed
16	18	22		Function, reset, internal programs
			000-009	No Function
			010-019	Blackout with Pan/Tilt Movement
			020-029	Blackout with Color Wheel Movement
			030-039	Blackout with Gobo Wheel Movement
			040-059	Color and Gobo Motor Reset
			060-069	Prism Motor Reset
			070-079	Pan & Tilt Motor Reset
			080-089	Focus Motor Reset
			090-099	All Motors Reset
			100-119	Internal Program 1 (Scene 1~8 of EEPROM)
			120-139	Internal Program 2 (Scene 9~16 of EEPROM)
			140-159	Internal Program 3 (Scene 17~24 of EEPROM)
			160-179	Internal Program 4 (Scene 25~32 of EEPROM)
			180-199	Internal Program 5 (Scene 33~40 of EEPROM)
200-219	Internal Program 6 (Scene 41~48 of EEPROM)			
220-239	Internal Program 7 (Scene 49~56 of EEPROM)			
		240-255	No Function	

SPECIFICATIONS

Light Source:

- 200W Cool White LED Engine (50,000 hr.)

Features:

- Motorized Focus
- Motorized Zoom: 11 ~ 22-degrees plus 16-bit Fine Zoom
- 2 Prism FX: Rotating 5-facet Linear & rotating 6-facet Circular
- 0-100% smooth dimming
- Various strobe speeds
- USB firmware update port
- 2 cooling fans

Color Wheel:

- 8 dichroic colors + white

GOBO Wheel:

- 6 aluminum GOBOs + open
- All GOBOs removable & rotatable
- GOBO Shake Effect
- GOBO size: 22.5mm (outer); 19mm (viewable); 0.5-2mm (thickness)

Prism Wheel:

- Prism Wheel 1: Rotatable 5-facet Linear
- Prism Wheel 2: Rotatable 6-facet Circular
- Prism Indexing

Control:

- 3 DMX Channel Modes: 16/18/22 Channels
- Color LCD display with 6-button function menu
- Data In/Out: 5-pin DMX
- Power In/Out: Locking power In/Out connections (Daisy chain 4 units @ 120V; 10 units @ 240V)
- Control Mode: DMX512 or internal programs
- 6 Dimming Curve Modes: Standard, Stage, TV, Architectural, Theatre, Stage 2
- 0-100% smooth dimming
- Various strobe speeds
- USB firmware update port
- With Wired Digital Communication Network
- RDM (Remote Device Management)

Pan/Tilt:

- Pan: 540 & 630 degrees
- Tilt: 270 degrees

Dimensions & Weight:

- Dimension: (LxWxH) 181.5 x 278.6 x 457.4mm
- Weight: 10 kg.

What's Included:

- Omega Bracket
- 1,8m Locking Power cable

Rating/Approvals:

- cETLus approved (Control #4010765)

DIMENSION DRAWINGS

Dimensions not to scale

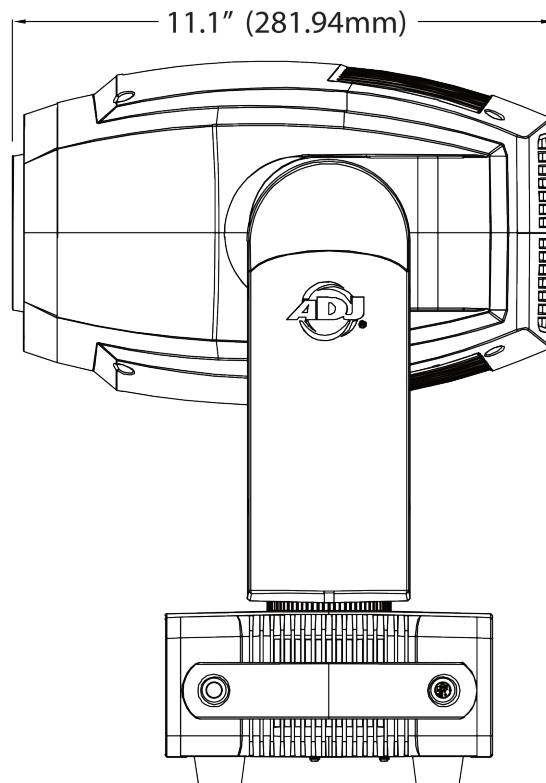
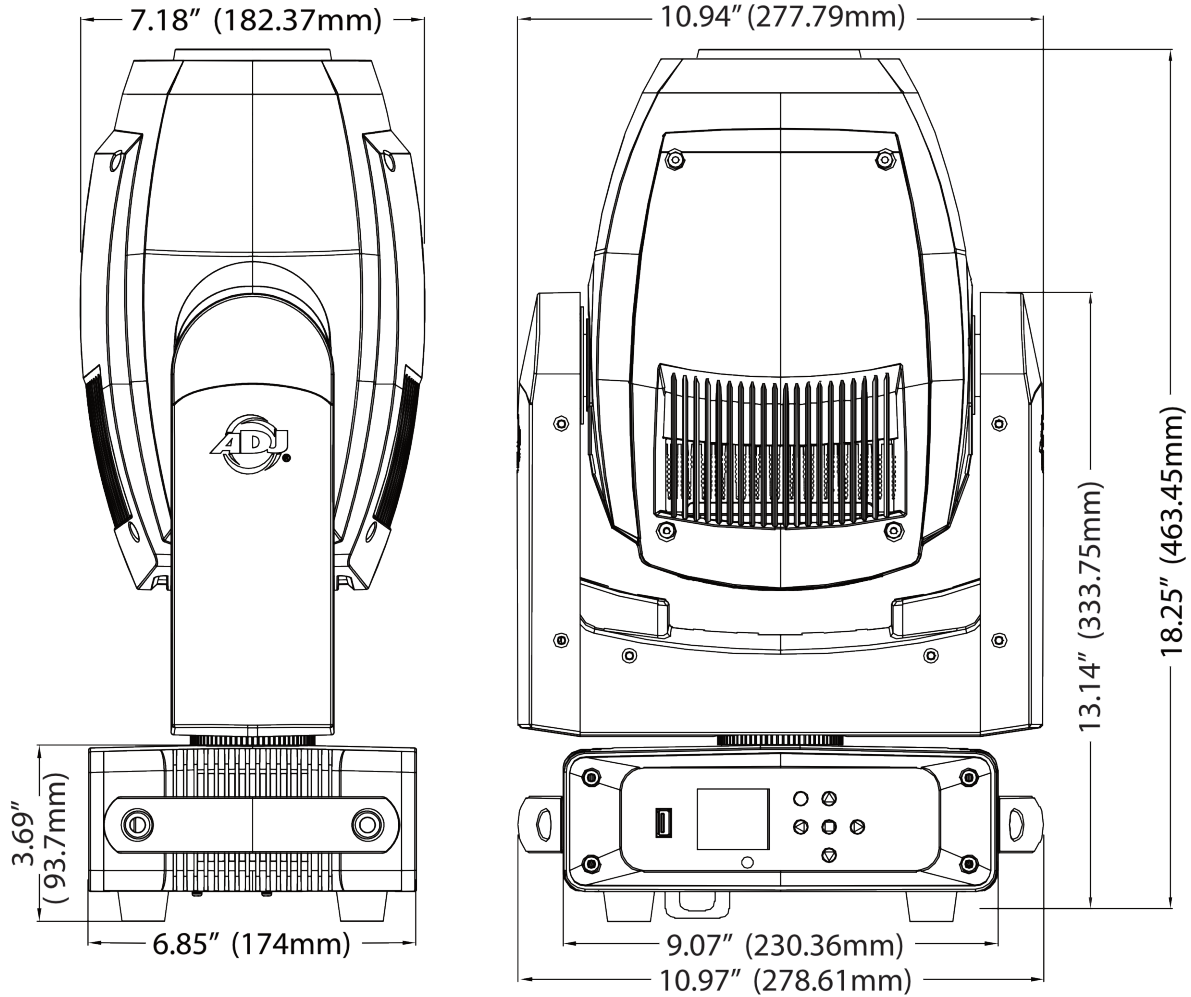

FCC STATEMENT

This device complies with Part 15 of the FCC Rules. Operation is subject to the following two conditions: (1) this device may not cause harmful interference, and (2) this device must accept any interference received, including interference that may cause undesired operation.

FCC RADIO FREQUENCY INTERFERENCE WARNINGS & INSTRUCTIONS

This product has been tested and found to comply with the limits as per Part 15 of the FCC Rules. These limits are designed to provide reasonable protection against harmful interference in a residential installation. This device uses and can radiate radio frequency energy and, if not installed and used in accordance with the included instructions, may cause harmful interference to radio communications. However, there is no guarantee that interference will not occur in a particular installation. If this device does cause harmful interference to radio or television reception, which can be determined by turning the device off and on, the user is encouraged to try to correct the interference by one or more of the following methods:

- Reorient or relocate the device.
- Increase the separation between the device and the receiver.
- Connect the device to an electrical outlet on a circuit different from which the radio receiver is connected.
- Consult the dealer or an experienced radio/TV technician for help.

Energy Saving Matters (EuP 2009/125/EC)

Saving electric energy is a key to help protecting the environment. Please turn off all electrical products when they are not in use. To avoid power consumption in idle mode, disconnect all electrical equipment from power when not in use. Thank you!



